



Playhouse

This design and detail is given for a playhouse to be erected on a flat level site. For sloping sites, modify the detail by embedding some of the posts deeper, or using posts of different lengths. However, remember that a playhouse which is close to ground is a safer playhouse.

TIMBER which is to be embedded in the ground should be of very durable quality. All other timber in the playhouse which is not in ground contact should be of durable quality but staining or painting is still recommended.

Consult your timber stockist on what timbers are available and suitable for this exterior exposed location. Construction should be as sketched in the exploded diagram. All fasteners should be galvanised (nuts, bolts, nails).

TOOLS YOU WILL NEED

- Saw 100 x 38mm,
- Carpenter's mitre square
- 2 pieces 2.4m DAR (joists)
- Measuring tape/rule and pencil
- Hammer and nail punch
- Electric drill and bits
- String line and level
- Spirit level
- Chisel

Materials you will need

Timber (N.B. All durable timber*)

- 75 x 75mm, 2 pieces 2.7m DAR (posts)
- 100 x 38mm, 2 pieces 2.4m DAR (joists)
- 75 x 25mm, T&G Flooring 34.8 lineal metres (or equivalent in 1.2m lengths)
- 100 x 25mm, 6 pieces 1.2m DAR (side rails)
- 100 x 38mm, 2 pieces 2.4m DAR (rafters)
- 50 x 38mm, 2 pieces 3.9m sawn (battens)
- 100 x 25mm, 39 pieces 1.2m sawn (roofing and gable)

Hardware

- 12/125 x 9mm galvanised cuphead nuts and washers
- 200/50 x 2.8mm galvanised flathead nails (roof, gables)
- 100/50 x 2.8mm galvanised bullet head nails (flooring nails)
- 20/65 x 3.15mm galvanised bullet head nails (floor, joists)

Note: Flooring and roof and gable timber - your timber stockist will supply long lengths of timber sufficient to cut these pieces. When ordering advise with order that your need is for lengths from which 1.2m pieces can be cut.

Alternative roof coverings:

- 2 sheets 1800 x 1200 x 6mm exterior grade plywood OR
- 1 sheet 3660 x 1220 x 9.5mm exterior grade hardboard

*Durable timber includes most native hardwoods, cypress pine, western red cedar, redwood, CCA treated hoop, slash or radiata pine. Consult timber stockist on suitability and availability.

MARK OUT position of posts on site using conventional string line and level method. Check that diagonals of the layout are equal - hence the 1200 x 1200mm area is square.



LINE LEVEL - Small tube level hangs from string line to determine level point at each corner and post.

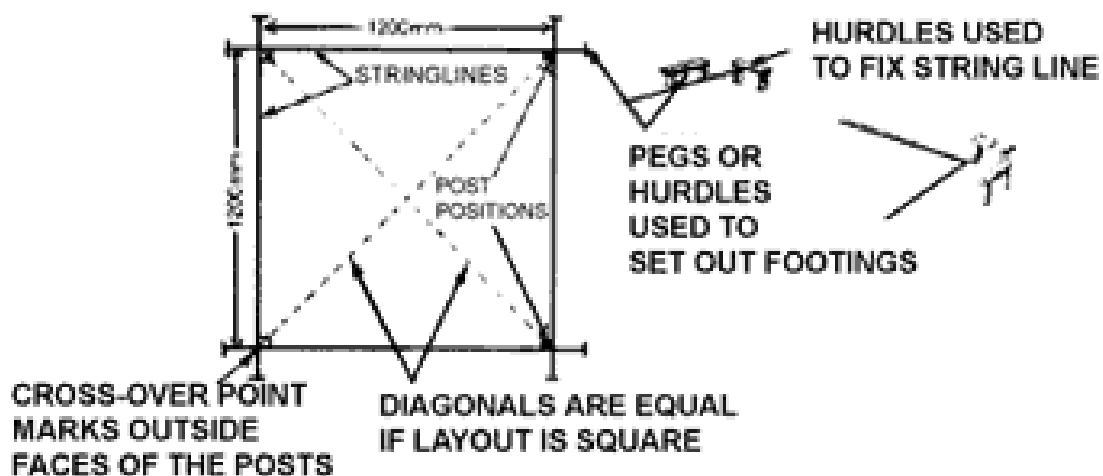

DIG HOLES for posts about 300 x 300mm in free draining soils. In clayey soils you may need to excavate deeper and infill with porous gravel or ashes or similar. Ram-pack base of hole.

CUT FOUR posts 'A' from the timber pieces 75 x 75 x 2.7m DAR and treat bottom 300mm with creosote or similar water repellent fungicidal material.

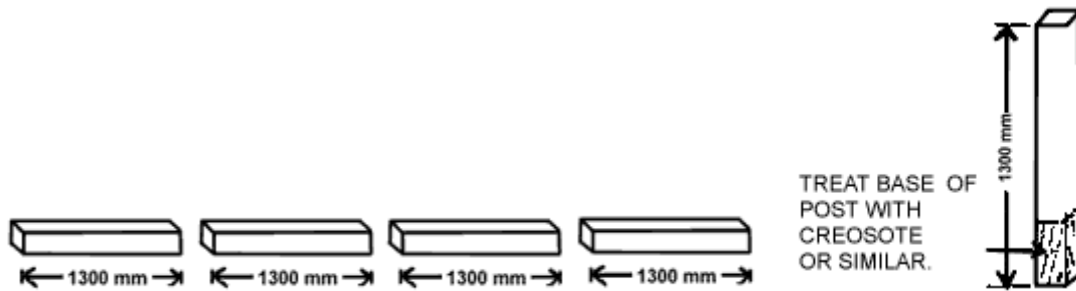

INSTALL POSTS in hole, keeping them vertical and in position with temporary braces. Note that tops of posts should be level. Ram-pack infill soil around post to about 150mm from ground line. Fill holes with concrete (as post collar) and allow two days to set before proceeding. (Note that the outside faces of the posts lie on a 1200 x 1200mm square). If possible retain bracing in position when proceeding with next step.

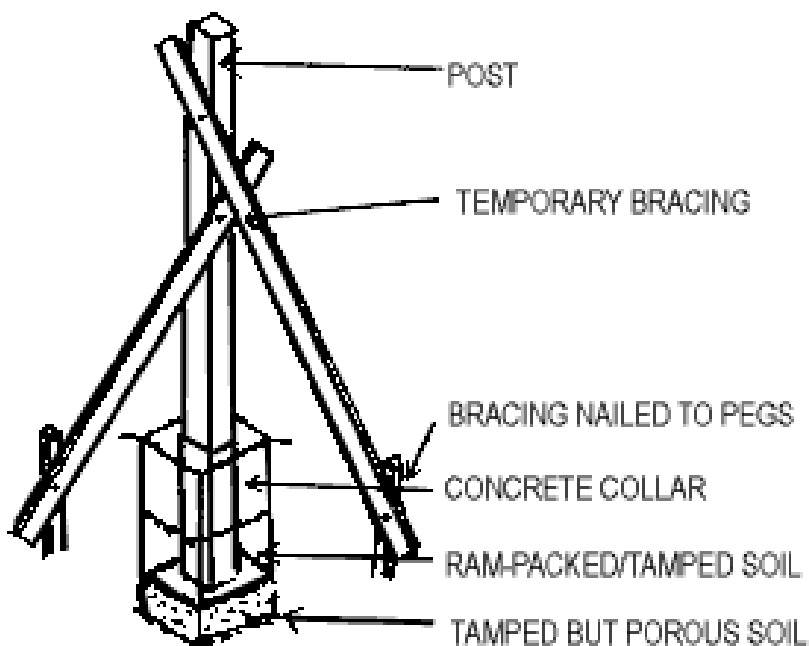

CUT FOUR floor joists 'B' 1200mm long from the timber pieces 100 x 38mm x 2.4m DAR.

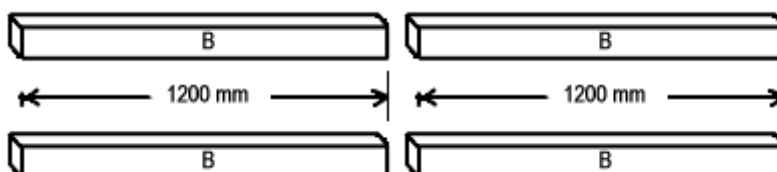

FIX FLOOR SUPPORT JOISTS: Nail these temporarily in position approx. 450mm above ground while levelness and squareness are checked - then drill bolt holes and fasten side floor joists permanently with bolts, nuts and washers. Permanently nail on front and back floor supports (refer to diagram) using 65mm nails.

FIX FLOOR SUPPORT JOISTS: Cut floor boards 'C' to length (1200mm) and fix to floor joists using two 50mm bullet head nails at each side joist and nails at 300mm centres across front and back floor rails. (Note: Loosely fit flooring before nailing and space out to allow for drainage through floor). Cut front and rear boards to fit around posts.

PREPARE ROOF RAFTERS 'D' as shown. First cut four rafters each 1200mm long from the two pieces 100 x 38mm x 2.4m. Then measure, mark, cut as shown below. Saw cut and chisel notches to fit battens tightly and flush with top edge of gable.

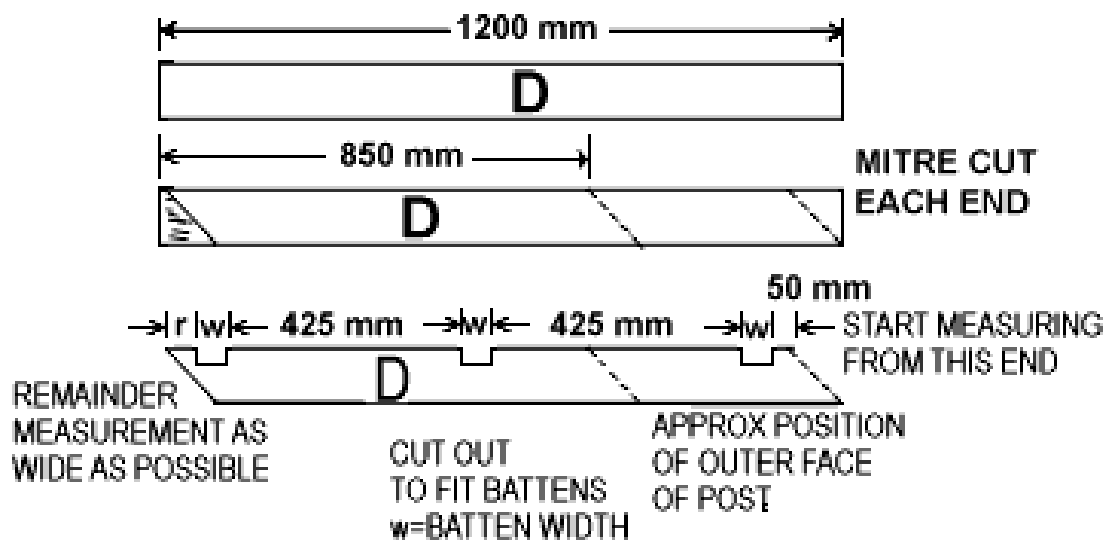

ASSEMBLE TWO gables/rafters on flat surface. Nail at peaks to hold while fixing gable ends, or temporarily brace using scrap timber between bottom of rafters.

CUT AND FIX GABLE ENDS: Cut the 100 x 25mm x 1.2m sawn boards (as below) to size and fix gable end boards to rafter using two flat head nails at each side. Fit five board

widths per gable end (N.B. See alternative roofing system). Cut the gable end boards from the 1.2m lengths of 100 x 25mm sawn timber or equivalent. Diagram shows how all pieces for both gables are cut from five pieces 1.2m long.

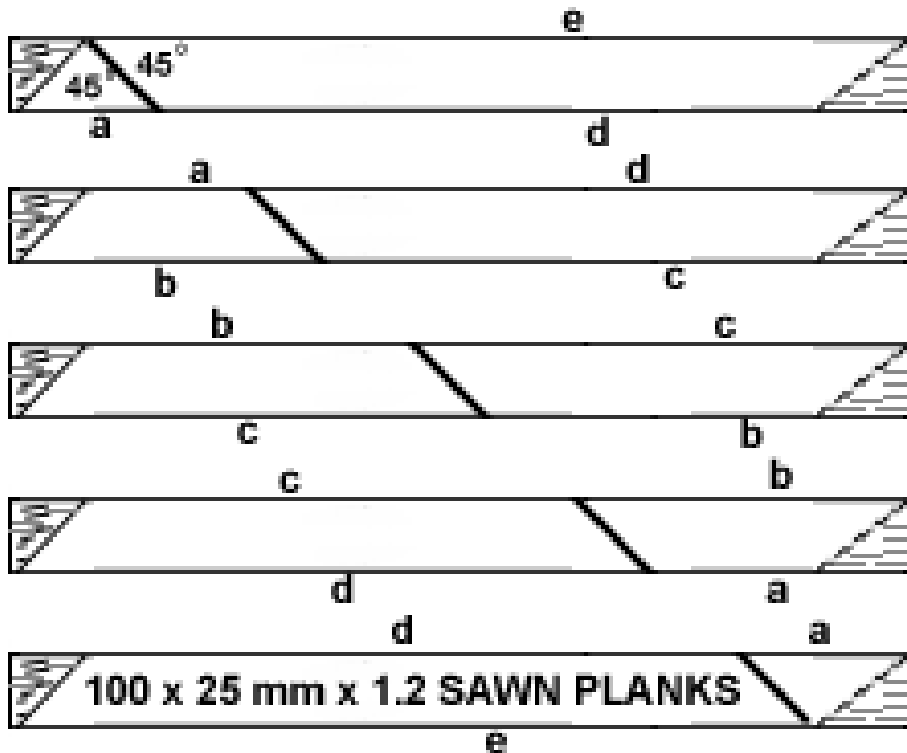

INSTALL GABLES using temporary nails before drilling and bolting in position. Tops of posts should be level and in line for accurate assembly to the line marked on the gable end.

CUT AND FIX BATTENS: Cut six battens 50 x 38 x 1275mm approx. To fit in rafter notches and nail in place using two nails at each rafter.

CUT AND FIX ROOFING BOARDS: Cut roof planks to 1200mm length and install the board roofing as shown in diagram over-lapping at apex as drawn. Observe gaps left between boards. Use nine planks or boards for the first layer. Fix front and rear boards first, using two flat head nails at each batten, allowing say 10mm projection or overhang of front and rear board out over front of gables. Then space remaining seven boards along roof. Repeat sequence on final layer using eight boards to cover the gaps left in the first layer (N.B. See alternative roofing system).

FIT SIDE/END RAILS; Cut six side and end rails 'E' each 1200mm long from the two 100 x 25mm x 3.6m DAR pieces. Nail side and back rails to posts as shown using 50 x 2.8mm nails.

Smooth down all rough surfaces with sanding disc on electric drill then stain, paint etc., with exterior quality finishes as described.

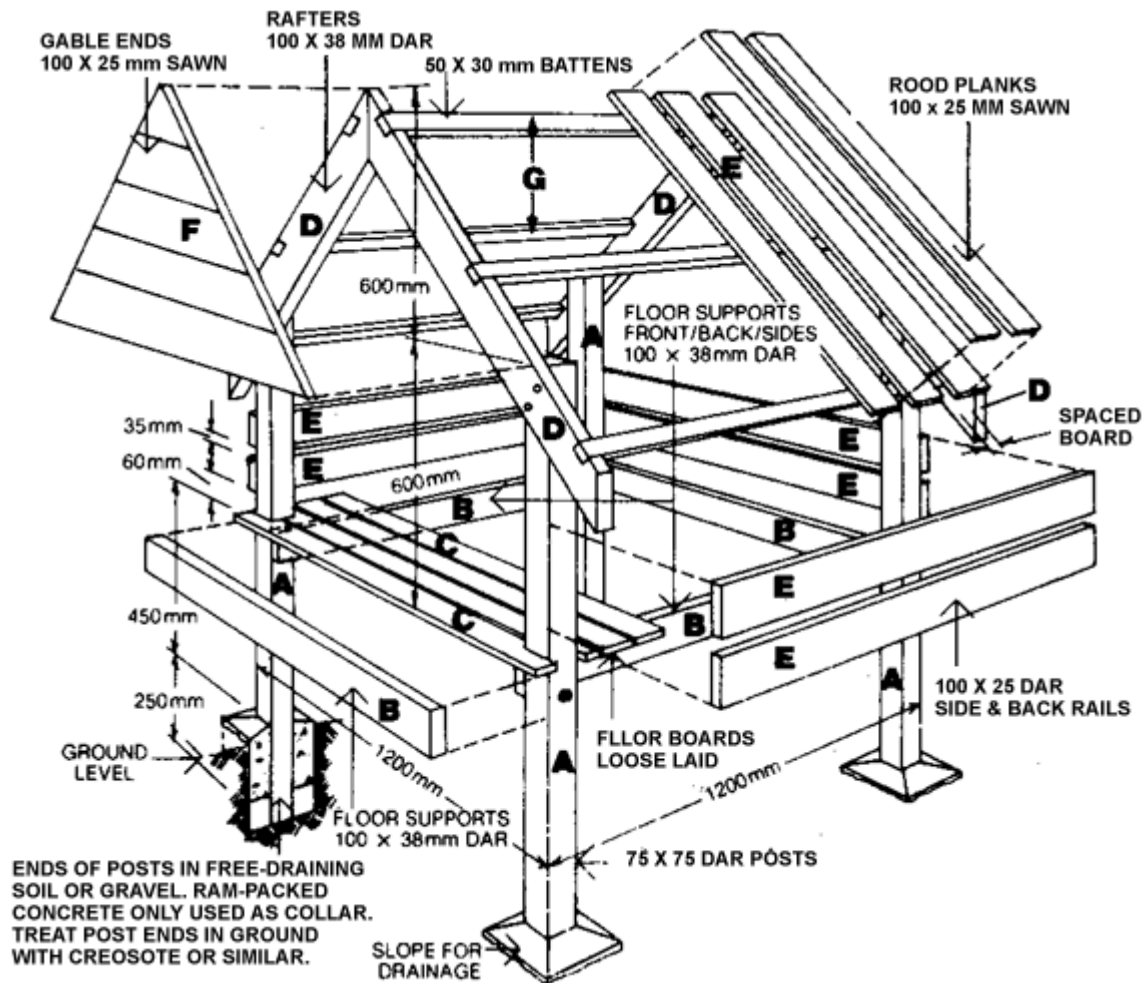

Alternative Roofing and Gable Ends

Instead of the 150 x 25 mm boards used as roofing which provide excellent insulation in roof against hot sun, exterior grade sheet material such as exterior grade 6mm thick plywood or exterior grade 9.5mm hardboard can be used. Sheet sizes available are shown in the materials list and these can be cut as these diagrams show. Fix all sheet materials used *flat* head nails.

Cutting Diagram for sheet roofing material

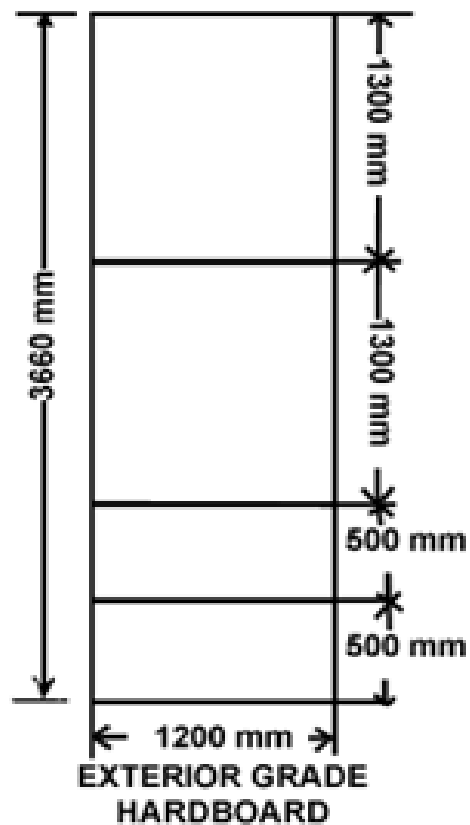
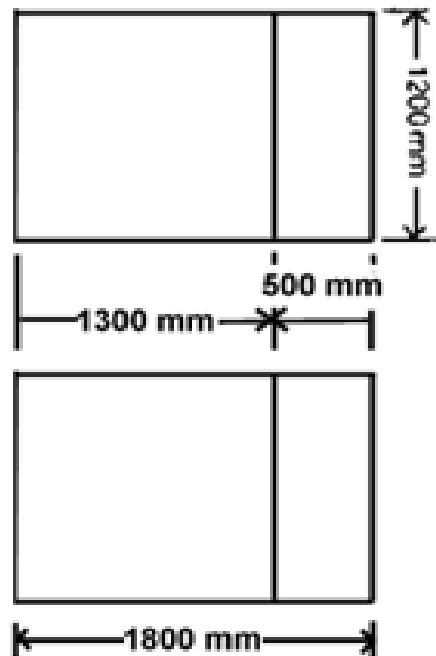
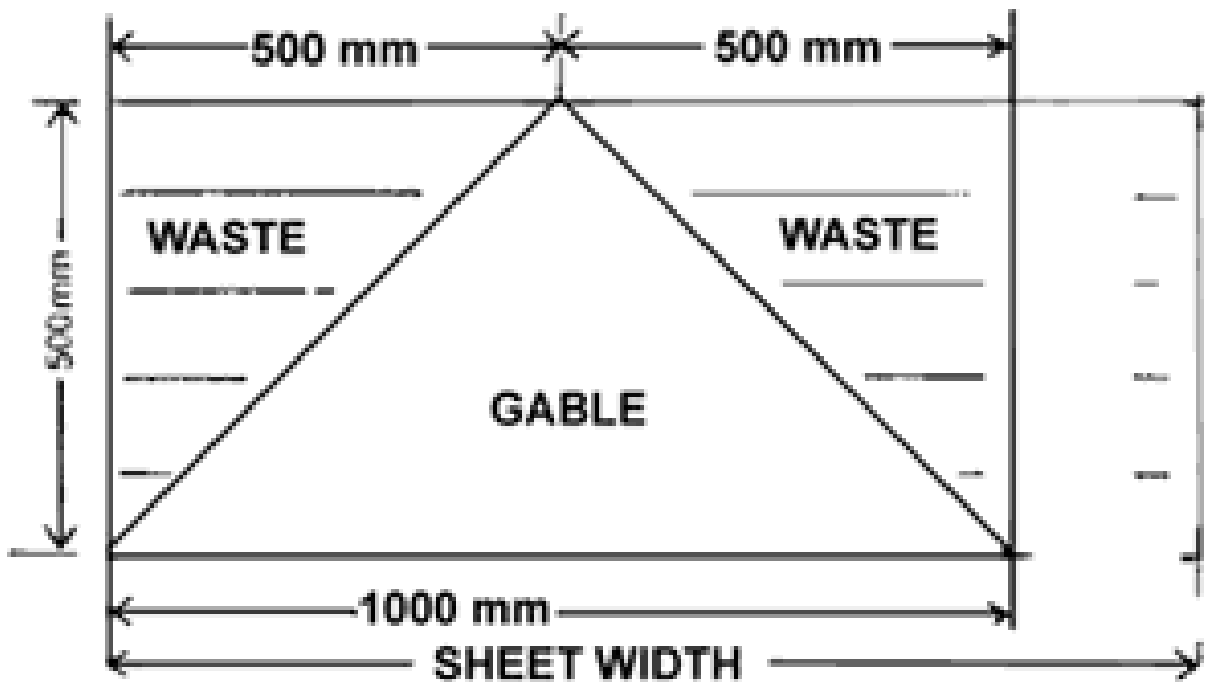

Using these materials you will need to cut the gable ends first from the small pieces 500 mm wide.

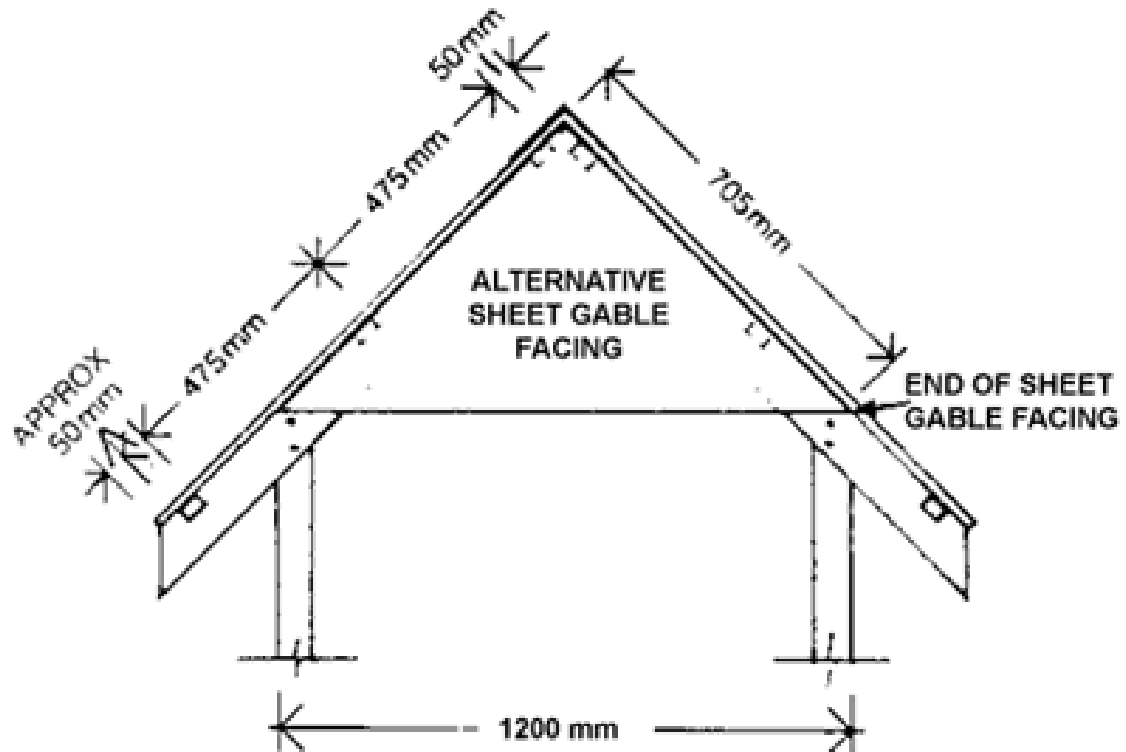

**RIDGE CAPPING MADE FROM
STANDARD WIDTH OR 200mm
WIDE DAMPCOURSE
ALUMINIUM SHEET OR
GALVANISED IRON**

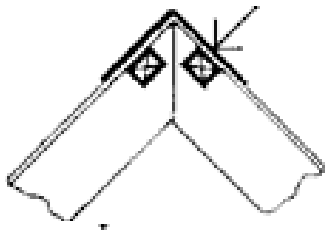

The larger 1300 mm long pieces would be fixed as shown here. Allow some small overhand at front and rear. If desired the lower gutter end of the sheet can be trimmed back to 50 mm from gable end. Using sheet material, a ridge capping of 200mm wide aluminium sheet or similar can be fitted.

